

Read this instruction carefully. See hardware and furniture part list for guidance. Be sure all parts are complete, before you assemble. Place all wooden furniture parts on a clean and flat soft surface to prevent from being scratched. Follow the figure to start assembling.

CAUTION : 1. Do not FULLY - TIGHTEN the nuts or nuts bolts until they are ready for assembly.
 2. Do not OVER - TIGHTEN the nuts or bolts to avoid causing damages to the thread.
 3. Keep all hardware parts out of reach of children.

NOTE : THE LIST AND QUANTITY SHOWN ARE FOR 1 UNIT ASSEMBLY.

Tools needed : Screwdriver (not provided).

PART LIST		
ITEM	DESCRIPTION	QTY
A	HEADBOARD	1 PC
B	FOOTBOARD	1 PC
C	BED LEG	2 PCS
D	SIDE RAIL	2 PCS
E	CENTER RAIL	1 PC
F	CENTER SUPPORT LEG	3 PCS
G	CENTER SUPPORT	2 PCS
H	BED SLAT	26 PCS

HARDWARE LIST		
ITEM	DESCRIPTION	QTY
1	JCBC BOLT M6 x 20mm	4 PCS
2	M6 SPRING WASHER	4 PCS
3	M8 SPRING WASHER	2 PCS
4	WOOD SCREW M4 x 20mm	8 PCS
5	WOOD SCREW M3.5 x 16mm	8 PCS
6	5/16" HEX NUT	2 PCS
7	VMB 3087 (BLACK)	2 PCS
8	SPANNER (13mm)	1 PC
9	M4 ALLEN KEY (BALL SHAPE)	1 PC
10	M5 ALLEN KEY (BALL SHAPE)	1 PC
11	M6 FLAT WASHER	4 PCS
12	BED SLAT SIDE FITTER	26 PCS
13	BED SLAT CENTER FITTER	13 PCS

STEP 1

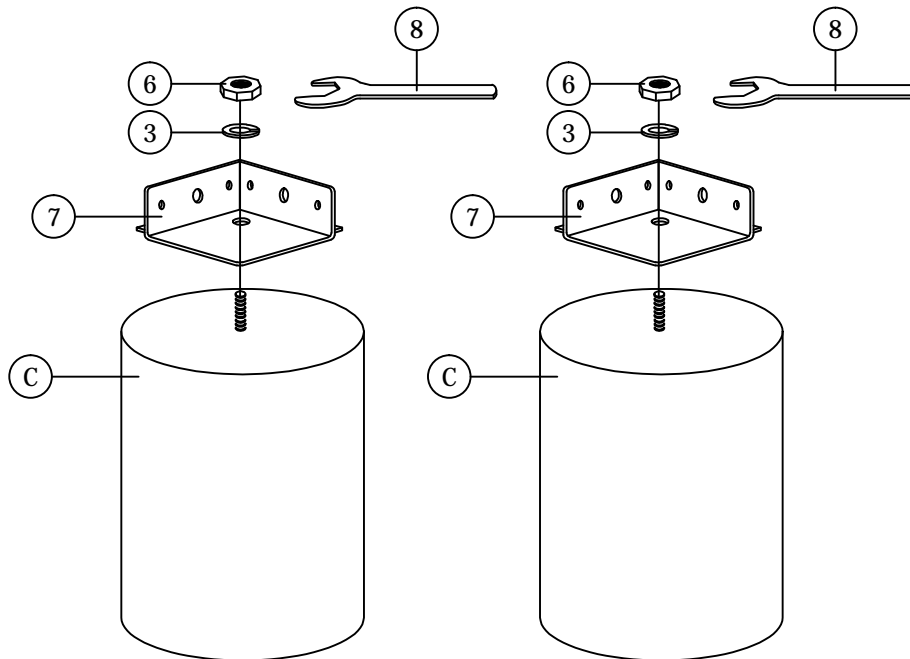

STEP 2

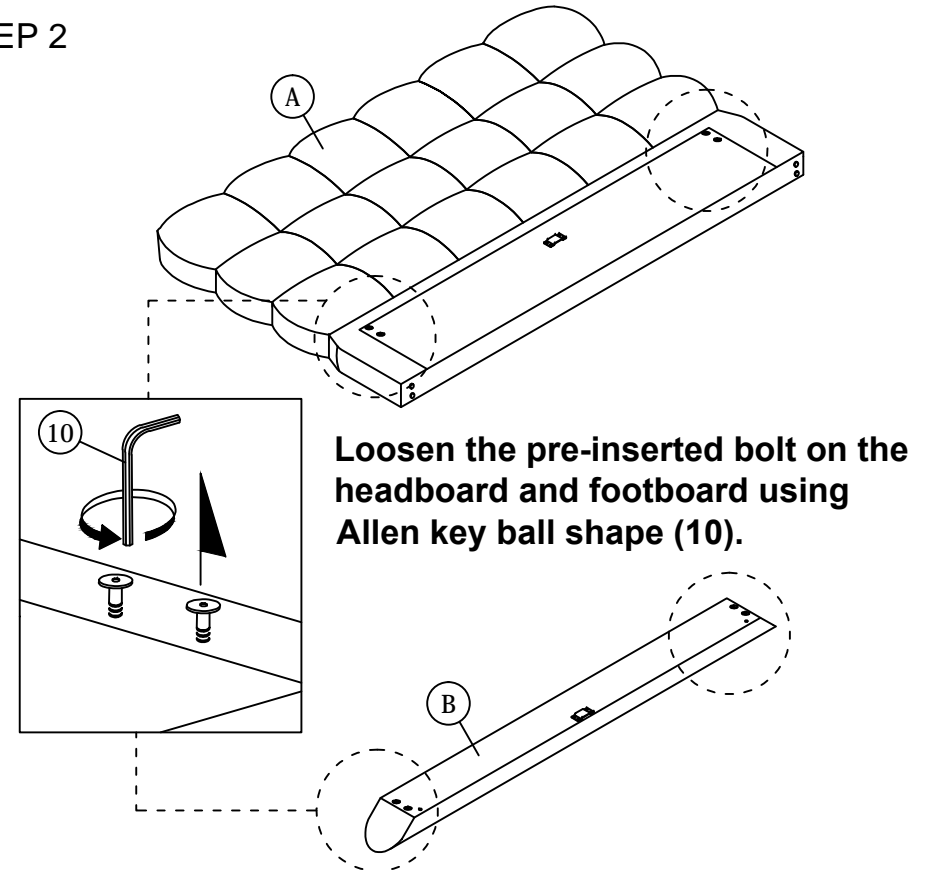

ASSEMBLY INSTRUCTIONS

STEP 3

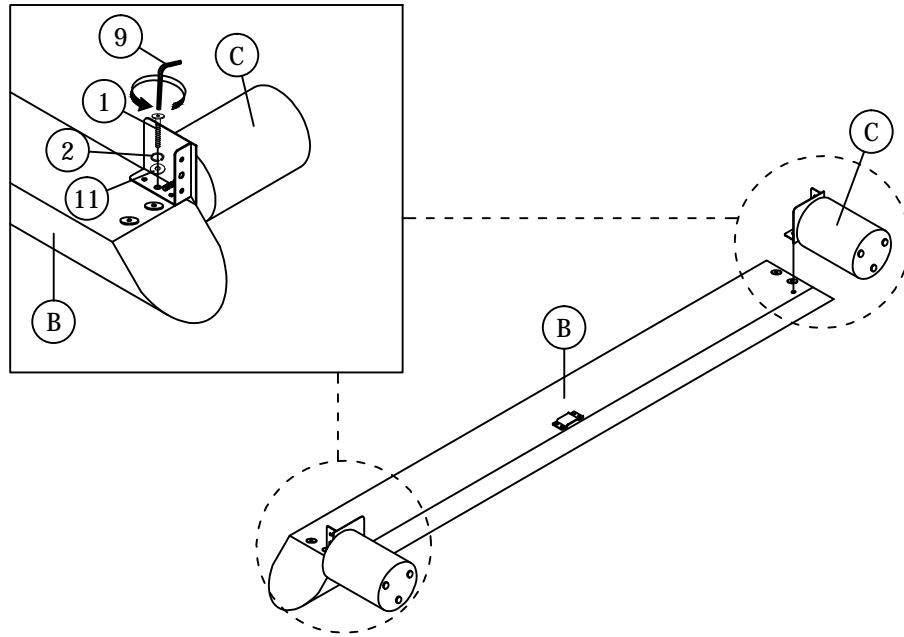

STEP 4

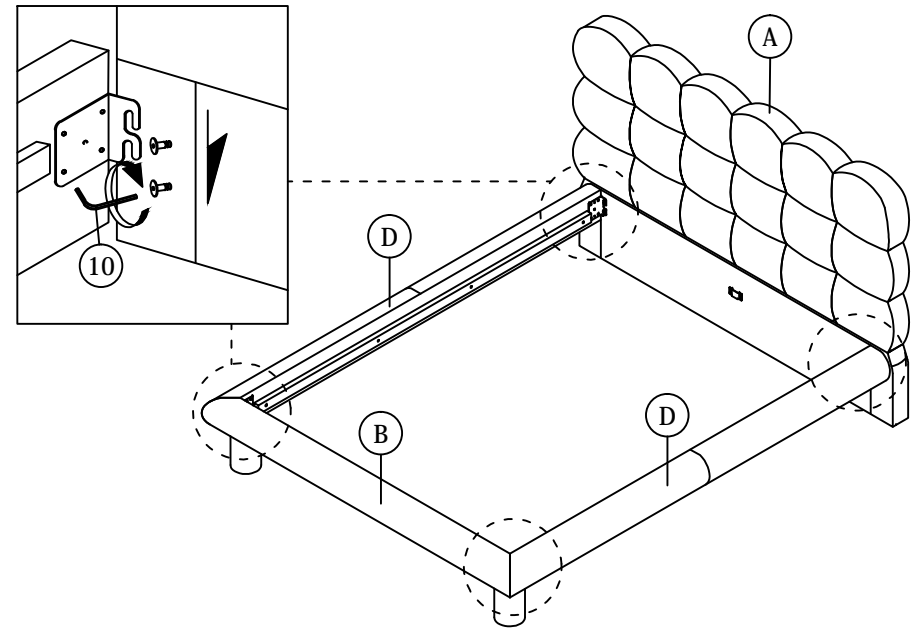

STEP 5

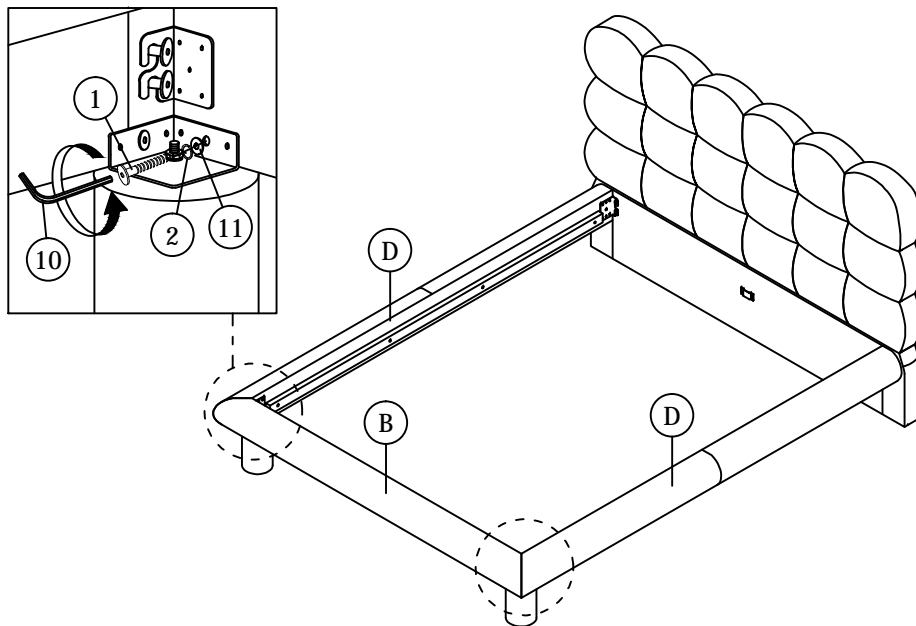

STEP 6

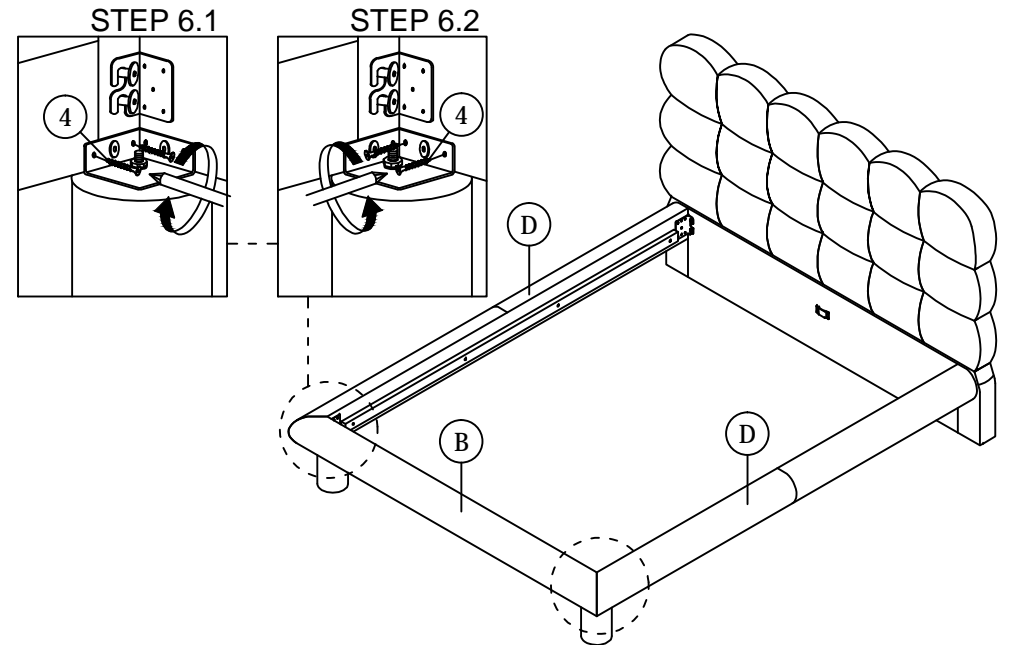

ASSEMBLY INSTRUCTIONS

STEP 7

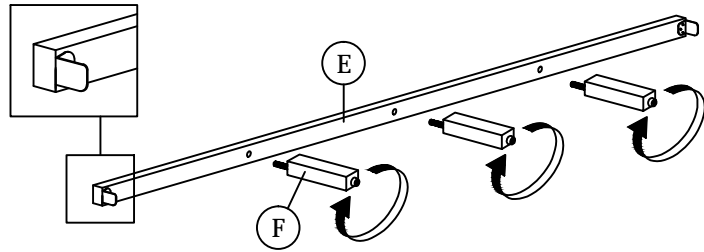

STEP 8

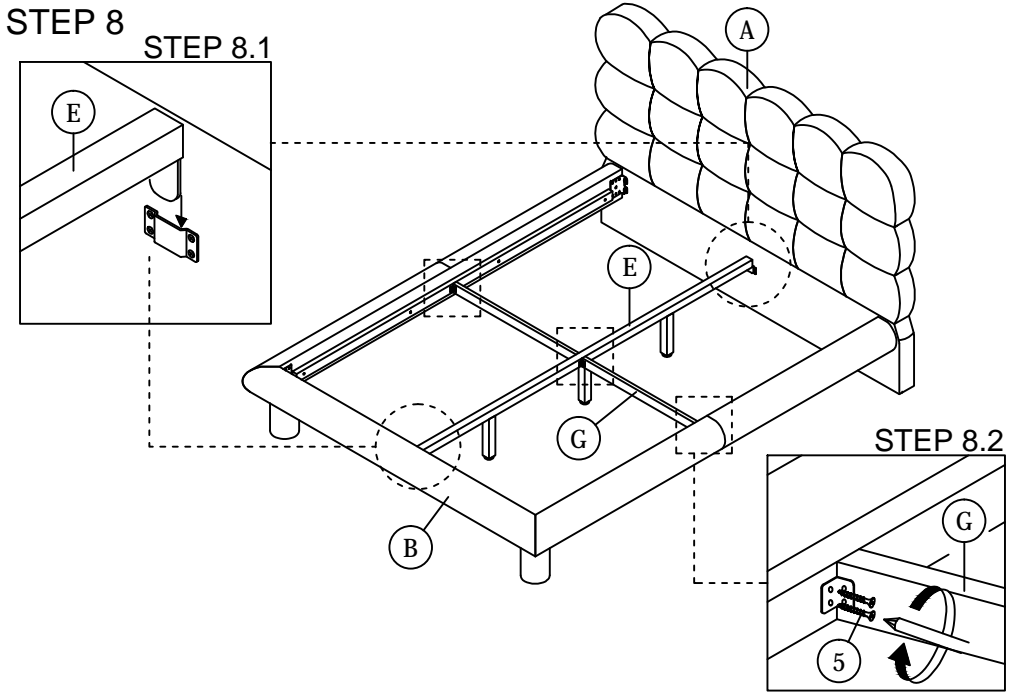

STEP 9

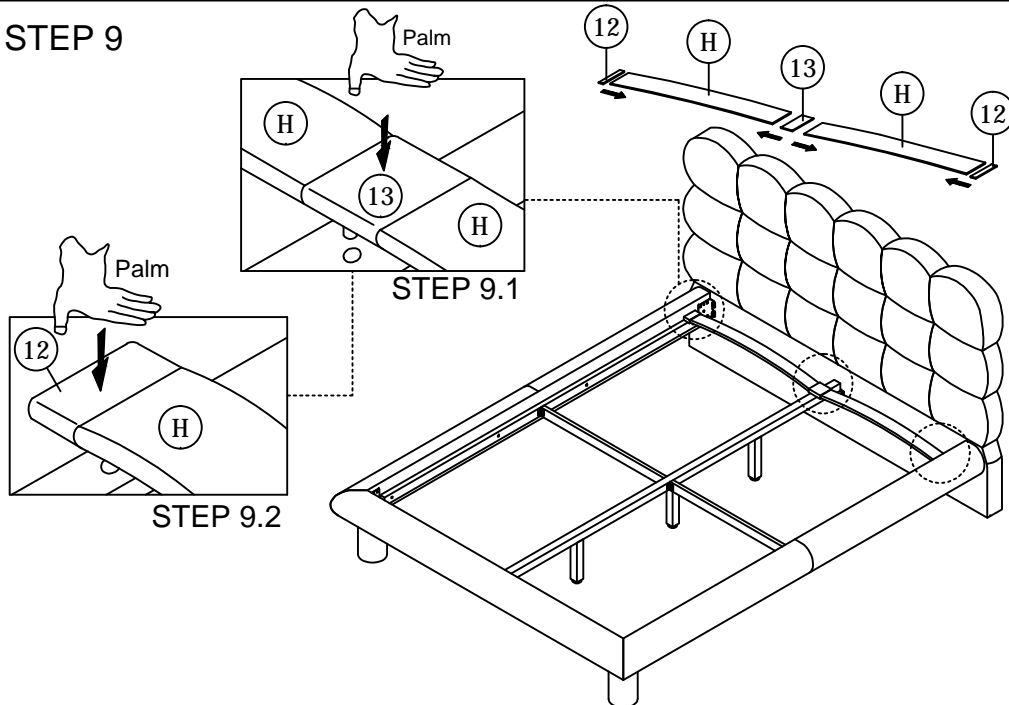

STEP 10

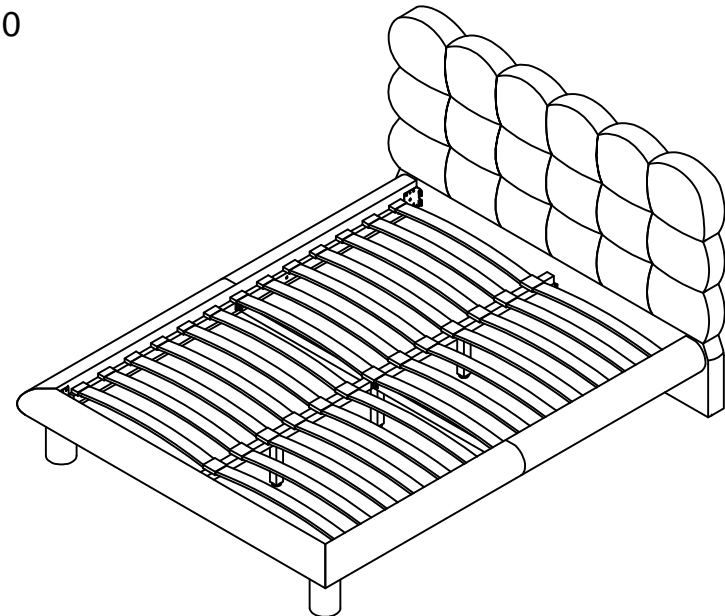

* When moving the bed position, the center support legs must be adjusted or straightened to avoid any broken problems.